

We invest in designs, technologies and capabilities that uphold our purpose and deliver a quality product

1

Tanks are available in different formats with a variety of fittings and accessories as per requirement

2

UV Stabilised outer layer that will withstand the harsh African climate

3

Greater thickness of polymer at the bottom of the tank to support pressure from liquid stored

4

Closely spaced ribs for added strength at the bottom of the tank

5

Comply with SANS 1731 : 2017

8

Quality control system in place to ensure our products meet specified design standards.

No vertical joints and weak spots

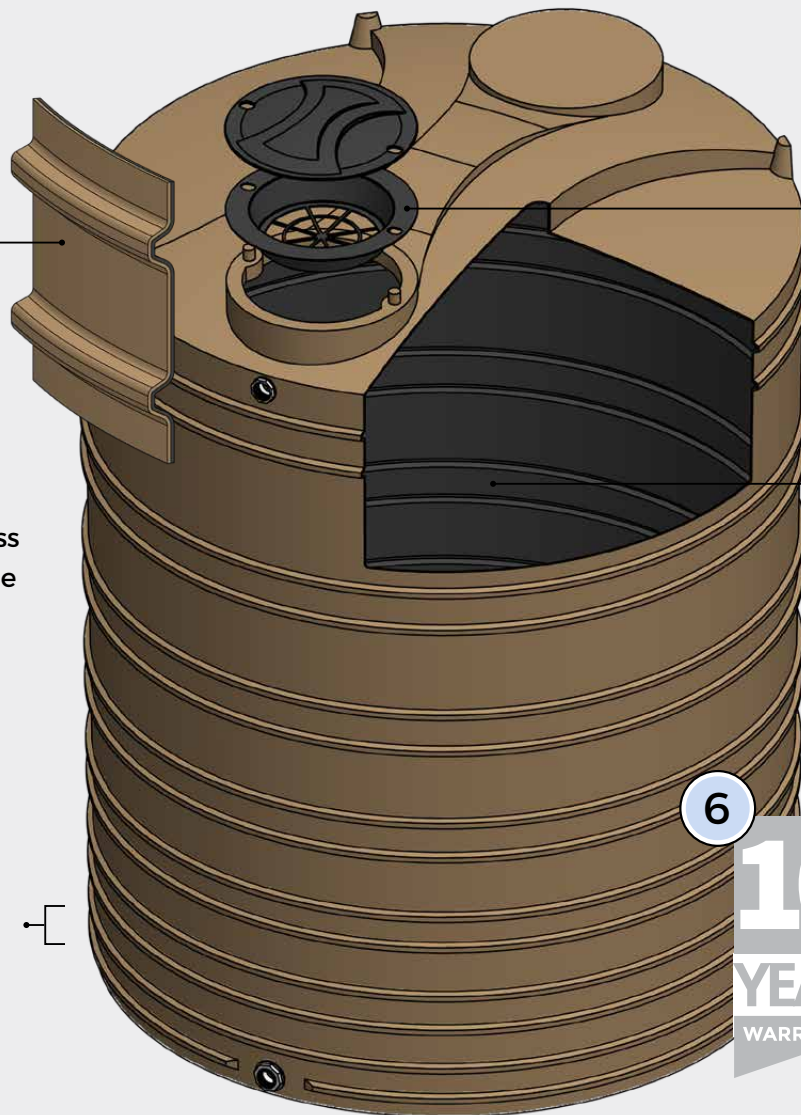

Note: Filter screen is optional

7

Black inner foodgrade liner to prevent algae growth and leaching of harmful chemicals

6

**10
YEAR
WARRANTY**

Warranties will be honored in accordance with specified procedures

After sales service

We have a dedicated helpline that is available during business hours.

On site inspections of tank related problems can be arranged in major urban markets.

Damaged tanks will be repaired (if possible), free of charge if tanks are delivered to an agreed JoJo Tanks service centre.

JoJo Tanks

OUR LEAD TIME & AVAILABILITY

COLOUR RANGE

WATER TANKS



JoJo Green



Wintergrass



Khaki Brown



Stormy Sky



Royal Blue



Red



Bushveld
Green



Black

CHEMICAL TANKS



White Natural



Blue Tint



Yellow Tint



Green Tint

MARBLE - FINISH**

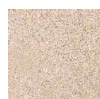

Sandstone

STOCK & NON-STOCK ICONS



This icon indicates that a product is carried in stock with a **7 calendar day** lead time, subject to delivery constraints.



This icon indicates a product that is non-stock i.e. made to order and has a **14 calendar day** lead time, subject to delivery constraints.

If neither of the above is listed next to a product, that product can only be ordered as a special order. Colour availability and lead time will then have to be confirmed with the relevant branch.

*Actual colours may vary

**Available with 10% premium

Note: All JoJo Tanks products can be made in any colours in the spectrum subject to practical terms and conditions. In fact special or customized colours can be accommodated subject to suitably large order size and negotiated lead time.

QUALITY GUARANTEE

All JoJo tanks are made from the best quality virgin food grade materials, are UV Resistant, BPA free and carry an 10 year guarantee.

Our high quality polyethylene products are perfectly suited to the numerous requirements of the agricultural, industrial and commercial industries and we also offer a range of products that are perfect for domestic needs.

Our specialist manufacturing practices and expertise guarantee quality, innovation and customised solutions. Accessories for all tanks are supplied.

JoJo Tanks



VERTICAL WATER TANKS



NEW

Try our brand new **Pump Ready Tanks**, pre-fitted with all required accessories/fittings to guarantee easy connection from tank to pump. Available in **750L Slimline™**, **1000L Slimline™**, **2500L MultiSlim™** & **2500L Vertical Tanks**.

Standard colours for vertical water tanks



Standard colour for the Slimline range



TANK	TYPE	SG	DIAMETER	HEIGHT	CLIP-ON LID	CODE	
260L	Standard	SG 1	620mm	925mm	480mm	260LT	S
500L	Standard	SG 1	840mm	1 080mm	480mm	500	S
750L Slimline™	Standard	SG 1	760mm	1 850mm	480mm	SLMB	S
750L Slimline™	Rainwater	SG 1	760mm	1 850mm	480mm & Sieve	SLM	S
+ 750L Slimline™	Pump Ready	SG 1	760mm	1 850mm	480mm	SLMCP1	S
1000L	Standard	SG 1	1 110mm	1 300mm	480mm	1000	S
1000L Slimline™	Standard	SG 1	840mm	2 060mm	480mm	1000SLMB	S
1000L Slimline™	Rainwater	SG 1	840mm	2 060mm	480mm & Sieve	1000SLM	S
+ 1000L Slimline™	Pump Ready	SG 1	840mm	2 060mm	480mm	1000SPRT	S
1500L	Standard	SG 1	1 410mm	1 200mm	480mm	1500	S
2200L	Standard	SG 1	1 420mm	1 700mm	480mm	2200	S
2500L	Standard	SG 1	1 420mm	1 860mm	480mm	2500	S
+ 2500L	Pump Ready	SG 1	1 420mm	1 860mm	480mm	2500P	NS
4500L	Standard	SG 1	1 820mm	2 060mm	480mm	4500	S
5000L	Standard	SG 1	1 820mm	2 255mm	480mm	5000	S
10 000L	Standard	SG 1	2 200mm	3 150mm	480mm	10000WA	NS
15 000L * **	Standard	SG 1	2 600mm	3 260mm	480mm	15000	NS
20 000L * **	Standard	SG 1	2 600mm	4 270mm	480mm	20000	NS

* Transport costs apply

** 50% Deposit required to confirm order

Jovo Tanks



VERTICAL TANKS CHEMICAL MEDIUM / HEAVY



Standard Colour

Stock items are subject to a 7 day calendar lead time



Alternative Colours

The following colours are also available at a 14 day calendar lead time



Important: Vertical Medium and Heavy duty strength variants are available as stock items in natural white, whilst other tints are available as non-stock items.

Note: The colours are “see through” allowing contents to be viewed.

TANK	TYPE	SG	DIAMETER	HEIGHT	SCREW LID	CODE	
260L	Chemical Medium	SG.1.4	620mm	925mm	450mm	260M	
	Chemical Heavy	SG.1.6	620mm	925mm	450mm	260H	
500L	Chemical Medium	SG.1.4	840mm	1 080mm	450mm	500M	
	Chemical Heavy	SG.1.6	840mm	1 080mm	450mm	500H	
1000L	Chemical Medium	SG.1.4	1 110mm	1 300mm	450mm	1000M	
	Chemical Heavy	SG.1.6	1 110mm	1 300mm	450mm	1000H	
1500L	Chemical Medium	SG.1.4	1 410mm	1 200mm	450mm	1500M	
	Chemical Heavy	SG.1.6	1 410mm	1 200mm	450mm	1500H	
2500L	Chemical Medium	SG.1.4	1 420mm	1 860mm	450mm	2500M	
	Chemical Heavy	SG.1.6	1 420mm	1 860mm	450mm	2500H	
5000L	Chemical Medium	SG.1.4	1 820mm	2 255mm	450mm	5000M	
	Chemical Heavy	SG.1.6	1 820mm	2 255mm	450mm	5000H	
10 000L	Chemical Medium	SG.1.4	2 200mm	3 150mm	450mm	10000M	
	Chemical Heavy	SG.1.6	2 200mm	3 150mm	450mm	10000H	
15 000L * **	Chemical Medium	SG.1.4	2 600mm	3 260mm	450mm	15000M	
	Chemical Heavy	SG.1.6	2 600mm	3 260mm	450mm	15000H	
20 000L * **	Chemical Medium	SG.1.4	2 600mm	4 270mm	450mm	20000M	
	Chemical Heavy	SG.1.6	2 600mm	4 270mm	450mm	20000H	

* Transport costs apply

** 50% Deposit required to confirm order

JoJo Tanks



NEW

2500L MULTISLIM™ TANK



DIMENSIONS

LENGTH	HEIGHT
2 500mm	1 960mm
WIDTH	SCREW-ON LIDS
760mm	2 x 450mm
PRODUCT	CODE
Standard	2500MSS
Rainwater *	2500MS
Pump Ready**	2500MSPRT

* Rainwater Tank fittings & accessories included
 ** Pump Ready Tank fittings & accessories included
 (See Vertical Water Tank section for more details)



Note: Fittings / Accessories differ for the three variants of the MultiSlim tank

LOW PROFILE TANKS

* Transport costs apply
 ** A lead time of 14 days required

TANK	TYPE	SG	DIAMETER	HEIGHT	LID	CODE	
5000L **	Standard	SG 1	2 230mm	1 560mm	480mm Clip-on Lid	5000LPW	
5000L **	Chemical Medium	SG 1.4	2 230mm	1 560mm	450mm Screw-on Lid	5000LPM	
5000L **	Chemical Heavy	SG 1.6	2 230mm	1 560mm	450mm Screw-on Lid	5000LPH	
10 000L * **	Standard	SG 1	2 420mm	2 550mm	480mm Clip-on-Lid	10000LPW	
10 000L * **	Chemical Medium	SG 1.4	2 420mm	2 550mm	450mm Screw-on Lid	10000LPM	
10 000L * **	Chemical Heavy	SG 1.6	2 420mm	2 550mm	450mm Screw-on Lid	10000LPH	

Note: All low profile tanks are non-stock items and are subject to a 14 calendar day lead time in the following colours:

Standard colours for water low profile tanks



Standard colours for chemical low profile tanks



JoJo Tanks uses a specialist roto-moulding manufacturing process that ensures quality, durability and the correct wall thickness. Temperature differences in the cooling process play an important role and this may result in a slight variance in tank size.



S 01 PUMP & TANK CONNECTOR KIT

All-in-one water pressure booster unit. A pump and tank connector kit that fits seamlessly onto your water tank to provide you with a pressured water feed.

CODE | PTT01

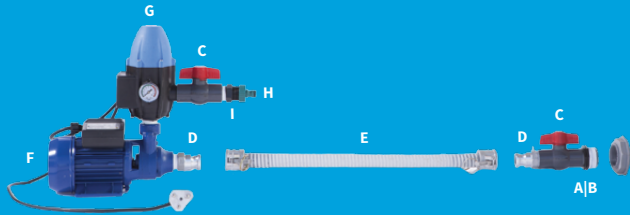

PUMP & TANK CONNECTOR KIT INCLUDES:

- A 40/25mm Reducer
- B 25mm Barrel Nipple
- C 2 x 25mm Ball Valves
- D 2 x 25mm Polyprop Male Couplers
- E Flexible Hose Assembly
Hose + 2 x Female Polyprop Couplers
- F Pump
- G Pressure Control Valve
- H 20mm Accessory Adaptor
- I 25/20mm Reducing Bush

S 02 PUMP TO TANK CONNECTOR KIT

An all-inclusive kit allowing seamless connection from tank to pump.

CODE | TCK01

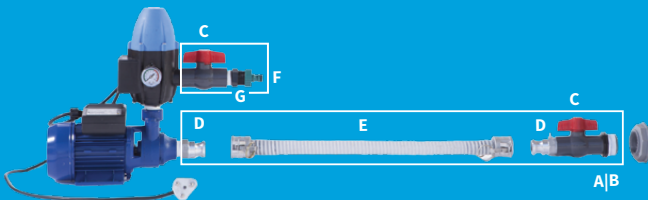

PUMP TO TANK CONNECTOR KIT INCLUDES:

- A 40/25mm Reducer
- B 25mm Barrel Nipple
- C 2 x 25mm Ball Valves
- D 2 x 25mm Polyprop Male Couplers
- E Flexible Hose Assembly
Hose + 2 x Female Polyprop Couplers
- F 20mm Accessory Adaptor
- G 25/20mm Reducing Bush

S 03 BOOSTER PUMP

Water pressure **Booster Pump** designed for boosting clean household water. It provides strong and reliable water pressure while using minimal energy.

CODE | PUMB

CLASS LEADING PERFORMANCE & DESIGN



- 4 Bar Pressure
- 40L/Min Flow
- 0.37kW
- Brass Impeller/Liner
- Stainless Shaft
- Dry running protection

NS 04 PUMP READY TANKS

Pump Ready Tanks are pre-fitted with a float valve and accessory adaptor.

For a complete solution, combine with a **Booster Pump** and a **Pump to Tank Connector Kit** (available separately) or the **Pump and Tank Connector Kit**.

Available in **750L Slimline™**, **1000L Slimline™**, **2500L MultiSlim** & **2500L Vertical Water Tanks**.



750L Slimline™ Pump Ready Tank in Wintergrass